

AMBUFRIDGE 7

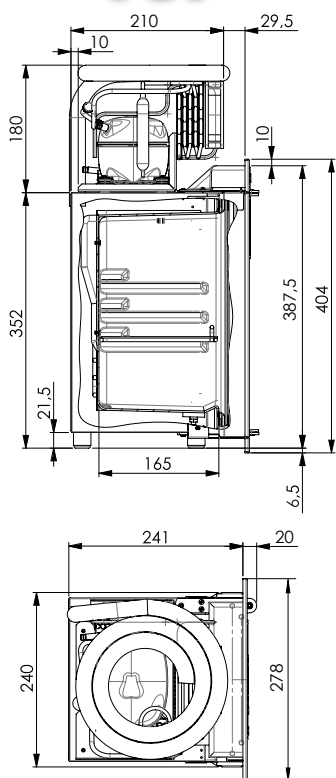

TOP



BACK

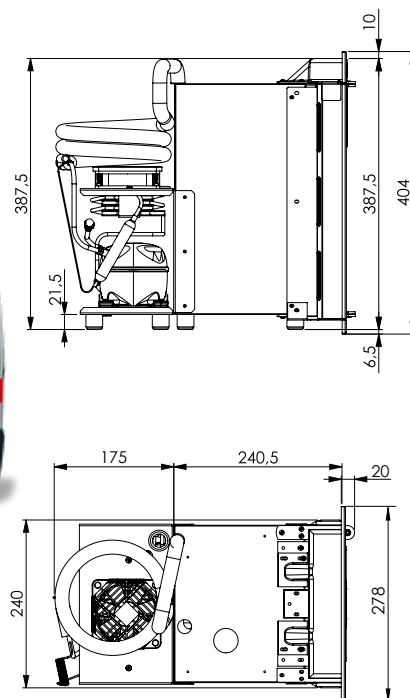



 Termostato elettronico con funzione on/off, temperatura fissa a 4°C +/- 1,5 °C, dotato di allarme acustico e visivo. Il frigo sarà pronto quando la spia verde smetterà di lampeggiare. Se viene superata la temperatura impostata, viene visualizzata la spia rossa e l'allarme acustico. Sia l'allarme acustico che visivo possono essere azzerati premendo i tasti set per 5 secondi.

 Electronic thermostat with On/Off function, fixed temperature at 4°C +/- 1,5°C, equipped with sound and visual alarm. The fridge will be ready when the green light will stop blinking. Red light and sound alarm will appear if set temperature is exceeded. Both sound and visual alarms can be reset pushing both the set buttons for 5 seconds.

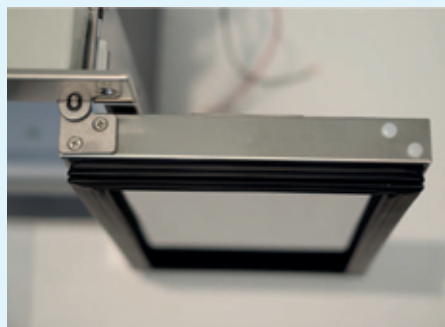

 Apertura anta reversibile 180°

 Reversible 180° door opening.



 Maniglia a incasso in acciaio inox per scongiurare aperture accidentali.

 Flush mount stainless steel handle for a secure door fastening.



 Ventilatore interno con piastra di protezione in acciaio inox e mensola interna (tre posizioni).

 Internal ventilation fan with stainless steel protection plate and internal shelf (three positions).



 Copertura di protezione sigillata per scheda elettronica e robusto telaio per montaggio a filo.

 Sealed protection cover for electronic board and strong flush mount frame.



 La nuova unità compressore SECOP BD 1.4F può essere spostata facilmente dall'alto verso il basso sul retro o sui lati destro e sinistro.

 The New SECOP BD 1.4F compressor cooling unit can be easily moved from the top to the bottom on the back or both right and left sides.

Dati tecnici Technical data					
• Volume del vano refrigerato	• Peso netto	• Potenza media assorbita	• Tensione di alimentazione	• Temperatura preimpostata	• Gas refrigerante
• Volume of the cooled compartment	• Net weight	• Average power consumption	• Supply voltage	• Fixed point temperature	• Refrigerant gas
• 7 litri / liters	• 10,9 kg	• 36 W	• DC 12/24 V	• 4°C +/- 1,5°C	• R134a - CFC Free

L'azienda si riserva il diritto di modificare qualsiasi disegno del modello senza preavviso secondo la nostra politica di miglioramento continuo del design, della qualità e delle prestazioni.
The company reserves the right to modify any design in the model without prior notice as per our policy of continuous improvement of design, quality and performance.



AUTOCLIMA S.p.A. a socio unico
Via Cavalieri di Vittorio Veneto, 15 - 10020 Cambiano (TO) - ITALY
Tel. +39 011 9443210 - Fax +39 011 9443230
sales@autoclima.com - www.autoclima.com